

2.0 APPLICABLE DOCUMENTS: (Per latest revision on date of order):

<u>Military</u>	Day					Revision
-----------------	-----	--	--	--	--	----------

MIL-Handbook-217	Reliability Predictions for Electronic Equipment
------------------	--

Underwriters Laboratories, Inc.

UL-STD-94	Tests for Flammability of Plastic Materials for Parts in Devices and Appliances
-----------	---

UL-STD-1950	Information Technology Equipment, Including Business Systems
-------------	--

3.0 REQUIREMENTS:

3.1 Mechanical:

3.1.1 Material:

3.1.1.1 Bearings: Single row ball bearing. Permanently lubricated shielded ball bearings: ABEC3 or better. Bearings are to be preloaded axially to prevent axial motion of shaft up to the force limit in the specification.

3.1.1.2 Bearing Lubrication: Lithium based grease. Grease shall have minimum shelf life in bearing of 18 months.

3.1.1.3 Shaft: Nonmagnetic Stainless Steel, 303 series.

3.1.1.4 End Bell: Aluminum Alloy.

3.1.1.5 Coil Insulation: Class 105 or better per UL-STD-1950 or Class UL-A.

3.1.1.6 Lead Wire:

A. Type: 24-26 AWG stranded, UL Style 3265 or UL 1007, CSA AWM.

B. Color:

Phase	A	B	A	B
-------	---	---	---	---

- 3.1.1.8 Connector: Receptacle Housing, Single Row, 4 Pin, .100CC, Polarized with Latch, Amp p/n 104257-3 or equivalent.
- 3.1.1.9 Contact: Crimp, 22-26 AWG, Short Point, Snap-In, Amp p/n 104480-8, or equivalent
- 3.1.1.10 Connectors and receptacles – primary connectors need to be recognized components found in section RTRT2 of the Recognized Component Directory and be evaluated to Canadian requirements. Connectors in low voltage secondary circuits also need adhere to the same requirements as the primary connectors. These requirements need to be detailed in Certificates of Compliance that is received with every shipment of material.
- 3.1.2 Corrosion Protection/Finish:
 - 3.1.2.1 Aluminum: No coating, as cast or machined.
 - 3.1.2.2 Steel-Carbon: All exposed surfaces shall be protected from corrosion.
 - 3.1.2.3 Stainless Steel: None.
 - 3.1.2.4 Laminations: All exposed surfaces shall be protected from corrosion.
- 3.1.3 Step Angle: 1.8 °s nominal; positional accuracy per 3.3.4. Stepping sequence per Table I.
- 3.1.4 Number of Phases: 2.
- 3.1.5 Mass: 0.27 kg
- 3.1.6 End Play: Shaft must not move more than 80 µm (0.004 in.) with 450 gf (15.8 ozf) lbs. force applied in the axial direction.
- 3.1.7 Radial Play: No more than 20 µm (0.0008 in.) with a 450 gf (15.8 ozf) force applied to the motor shaft in the radial direction.
- 3.1.8 Bearing Life: 5,000 hours minimum life at 1000 full-steps per second.
- 3.1.9 Rotating Parts: The rotating parts of this motor shall have a moment of inertia of 48 g-cm².

3.2.4 Coil Inductance / Phase (measured with 1.0 Volt rms at 1,000 Hz): 5.0 millihenries max.

3.2.5 Dielectric Strength: 100 megohms minimum with 500 VDC applied between motor coils and stator laminations for a minimum of 60 seconds.

3.2.6 Pin Identification / Function: per Figure 1.

3.3 **Performance:** Motor shall have the specified positional accuracy under the conditions specified below:

3.3.1 Load: External inertial load is 9800 g-cm². The gear ratio is 4:1. The ratio of reflected inertial load to the motor inertia is approximately 14:1. The frictional torque load shall be 1000 g-cm² maximum.

3.3.3 Duty Cycle: The motor shall have 50% duty cycle at 50°C (ambient) maximum, with a maximum coil temperature rise of 50°C. Coil temperature shall be verified by the change of resistance method.

3.3.4 Positional Accuracy: The positional accuracy error is non-cumulative. Full-step mode is with two phase drive scheme. Accuracy shall be 1.8 ° ± 5% in full-step mode.

3.3.5 Environment: The stepper motor shall operate and maintain positional accuracy within the temperature and humidity ranges as listed in this specification.

3.3.6 Holding Torque: 0.314 N-m (3.2 kgf-cm) minimum, 1.7 A / phase, 2 phase exciting.

3.3.7 Dynamic Torque: Torque is measured in full step mode, with 12.0 VDC applied to motor terminals.

Pull-in Torque: It is the maximum torque at which a stepper motor will start and run in synchronism, without losing steps, at a given speed.

Pull-out Torque: It is the maximum torque that can be applied to the shaft, running at a given speed, and not cause it to lose steps. The stepper motor shall supply, as a minimum, the pull-in and pull-out torque as shown per Figure 2.

3.3.8 Detent Torque: 16 mN-m max.

3.3.9 Maximum Starting Pulse Rate: 1600 pps min., Half Step, No Load.

3.4 Environmental:

3.4.1 Temperature Range: (Air surrounding motor).

- A. Operating: +0°C to +50°C
- B. Non Operating: -20°C to +70°C

3.4.2 Humidity:

- A. Operating: 20% to 90%, non-condensing.
- B. Non Operating: 20% to 95% RH, non-condensing.

3.4.3 Altitude:

- A. Operating: Sea level to 8,000 ft.
- B. Non Operating: Sea level to 30,000 ft.

3.5 Flammability: Plastic materials used in construction of this item shall be rated 94V-2 or better, per UL-STD-94 and shall be UL Recognized.

3.6 Marking: Item shall be legibly and permanently marked with the supplier name or symbol, supplier part number, rated voltage, revision level and date code. Pin 1 of the cable connector must be clearly identified.

3.7 Workmanship: Item shall be uniform in quality and free from defects that adversely affect life, serviceability, performance, and appearance.

3.8 Packaging and Shipping: Item shall be properly packaged for protection against damage during handling, transit and storage. The container shall include the supplier name or symbol, supplier part number, date code, quantity, Quantum part number and part revision.

4.0 QUALITY ASSURANCE PROVISIONS:

Item submitted shall be initially approved by Quantum Corporation. Approval shall be given only after samples representative of the suppliers normal production run have been examined, tested and found to meet the requirements of this specification.

Approved suppliers who desire to make a change in the design, materials, or process control which impacts any requirements

TABLE I
STEPPING SEQUENCE

Phases (4)

CW STEPS	A	B	\bar{A}	\bar{B}	CCW STEPS
	Pin 1	Pin 3	Pin 2	Pin 4	
1	+	0	-	0	8
2	+	+	-	-	7
3	0	+	0	-	6
4	-	+	+	-	5
5	-	0	+	0	4
6	-	-	+	+	3
7	0	-	0	+	2
8	+	-	-	+	1

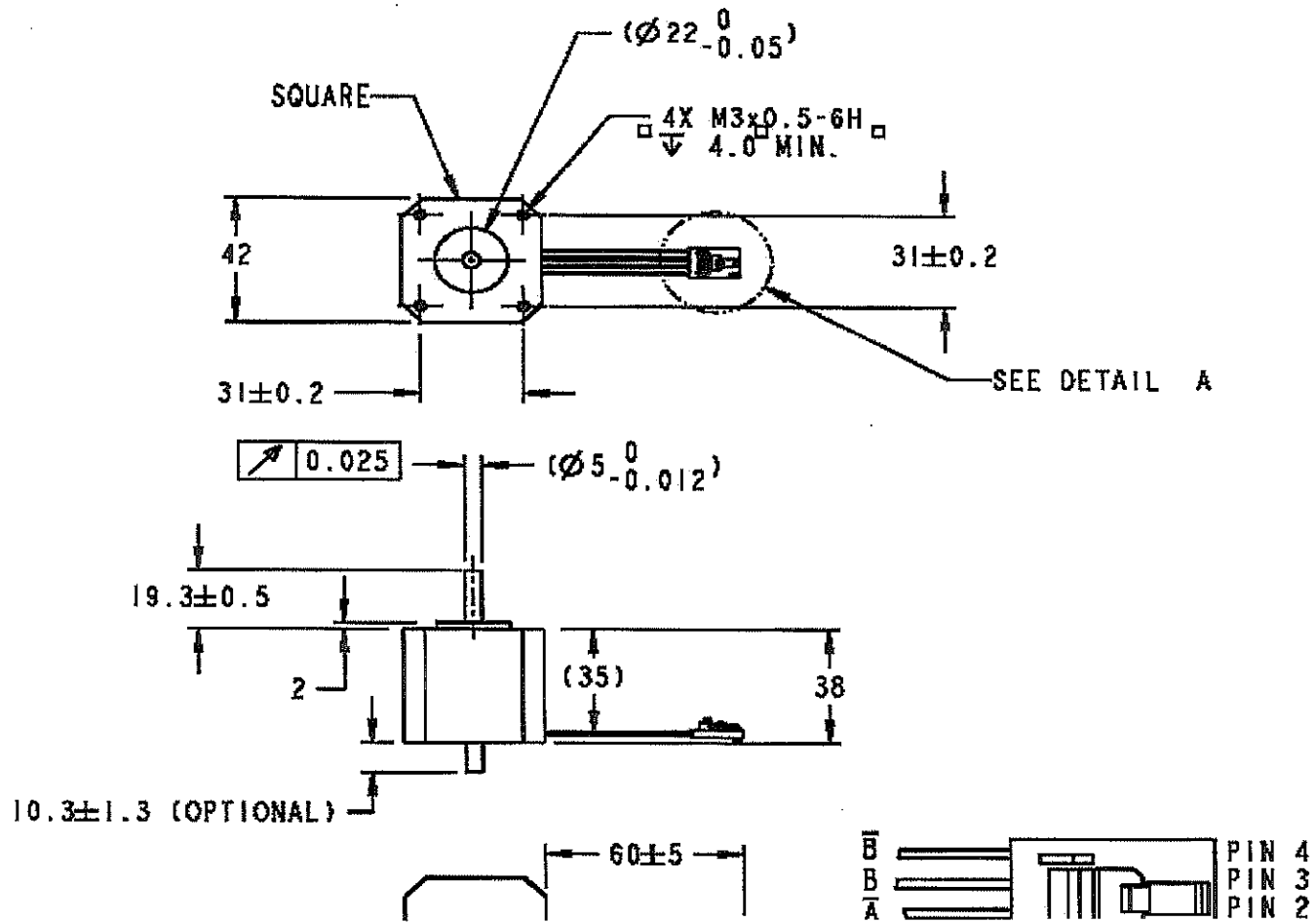

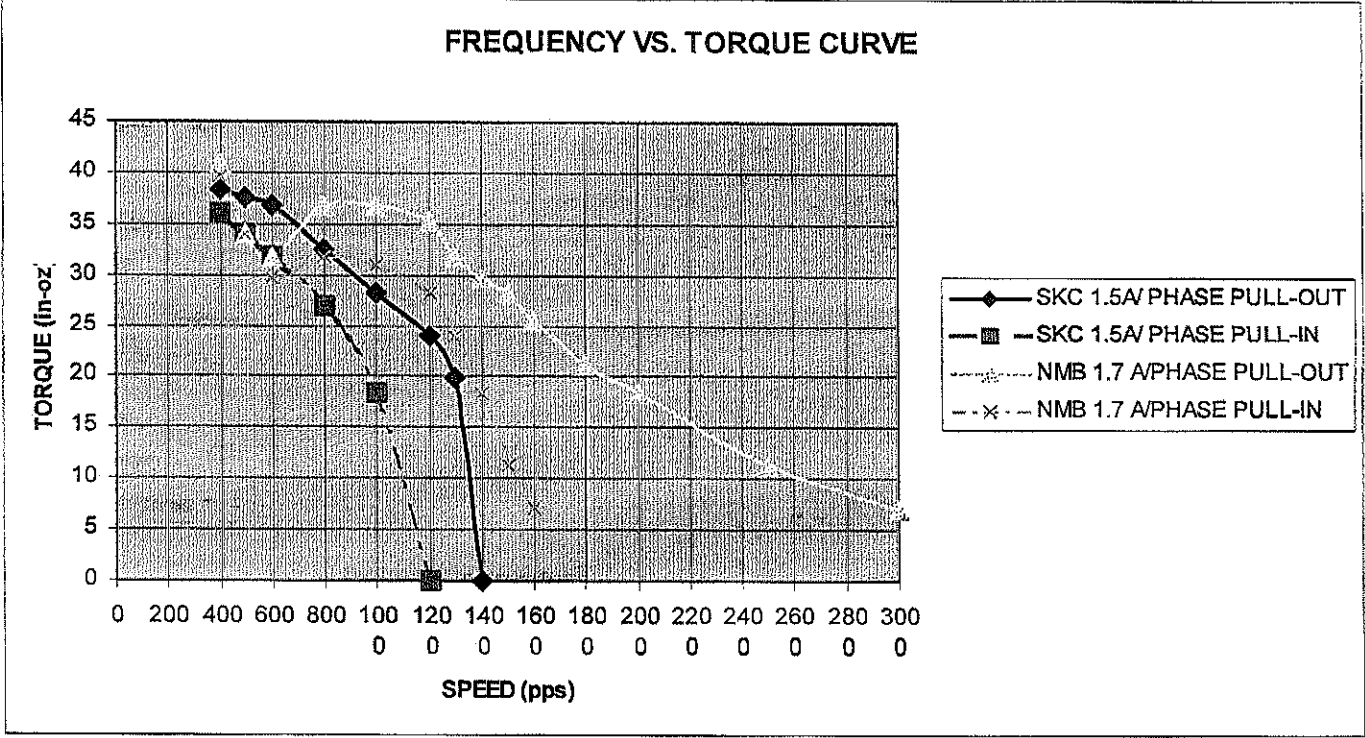

(AT FULL STEP)

FIGURE 2

FREQUENCY VS TORQUE CURVE