



IDA

INTERNATIONAL DISTRIBUTION ALLIANCE, INC.

Uniting business - one person at a time



BALL LINEAR GUIDES

FOR COMMERCIAL AND INDUSTRIAL APPLICATIONS

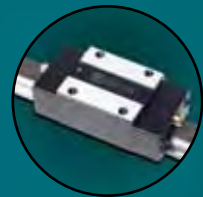

ORDERING INFORMATION



Features of ABBA Ball Linear Guides:

- Internal lubrication for longer life
- Size interchangeable with competing brands
- Available with wash-down, FDA approved Armoloy® coating

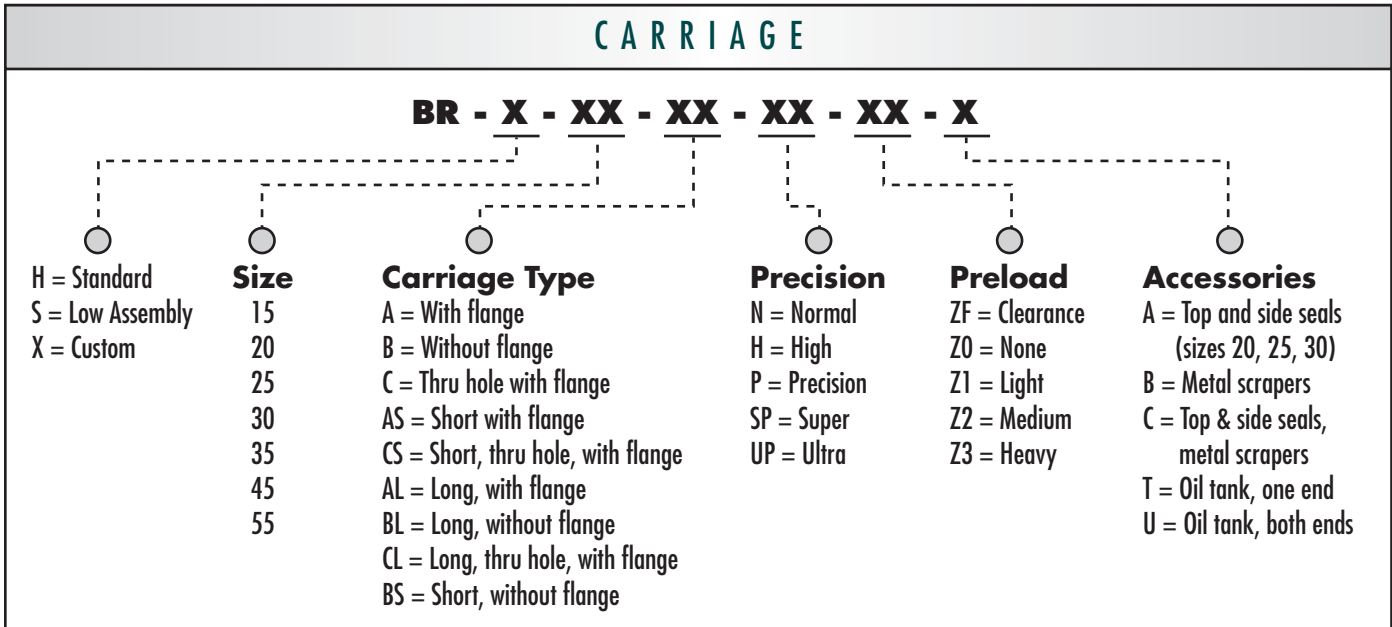

NOTES: 1. Size 15, 20, 25 and 30 carriages are provided standard with an internal lubrication part for extended life.
2. Size 55 carriages available with caged balls only.

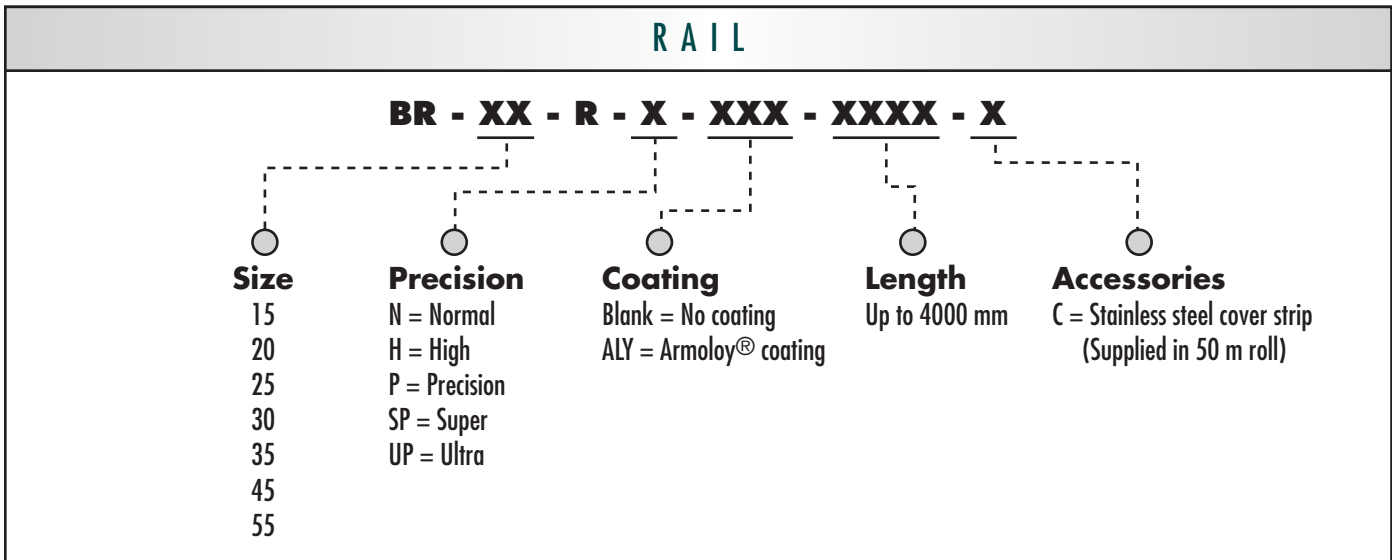

Armoloy® is a registered trademark of the Armoloy Corporation.

IDA, Inc. can accept no responsibility for possible errors in catalogs, brochures and other printed material. IDA, Inc. reserves the right to alter its products without notice. This also applies to products already on order provided that such alterations can be made without subsequent changes being necessary in specifications already agreed.

STANDARD, WITH FLANGE (BRH-XX-A & AL)

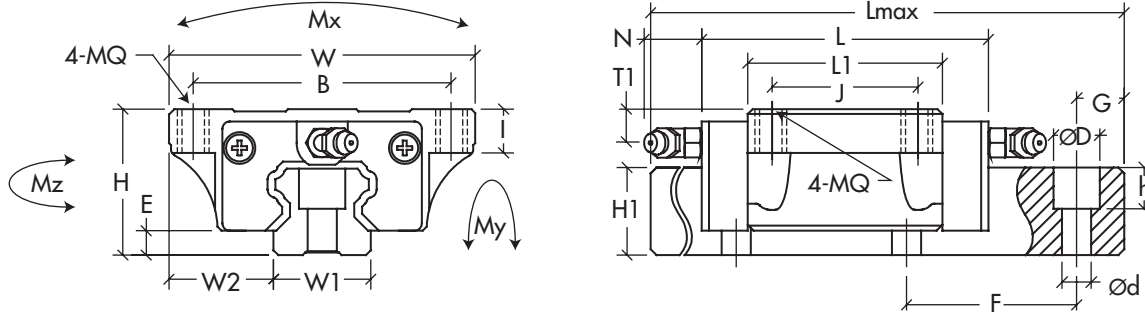

PART NUMBER	ASSEMBLY (mm)				CARRIAGE (mm)								RAIL (mm)					BASIC LOAD RATING (kg-f)		STATIC MOMENT (kg-f*m)			WEIGHT (kg-f)	
	H	W	W2	E	L	B x J	MQ x l	L1	Oil Hole	T1	N	W1	H1	F	d x D x h	Lmax	G	C	Co	Mx	My	Mz	CARRIAGE (kg-f)	RAIL (kg-f/m)
BRH15A	24	47	16	4.6	66	38 x 30	M5 x 8	40	ø3	4.3	5	15	14	60	4.5 x 7.5 x 5.3	4000	20	850	1650	10	8	8	0.21	1.4
BRH20A BRH20AL	30	63	21.5	5	77.8 92.4	53 x 40	M6 x 9	48.8 63.4	M6 x 1	5	6.5	20	18	60	6 x 9.5 x 8.5	4000	20	1450 1900	2560 3330	22 28.6	18 23.4	18 23.4	0.4 0.52	2.6
BRH25A BRH25AL	36	70	23.5	7	88 110.1	57 x 45	M8 x 12	57 79.1	M6 x 1	5	6.5	23	22	60	7 x 11 x 9	4000	20	2140 2996	4000 5600	36 50.4	32 44.8	31 43.4	0.57 0.72	3.6
BRH30A BRH30AL	42	90	31	9	109 131.3	72 x 52	M10 x 12	72 94.3	M6 x 1	7	6.5	28	26	80	9 x 14 x 12	4000	20	2980 3900	5490 7190	60 78.5	50 65	49 65	1.1 1.4	5.2
BRH35A BRH35AL	48	100	33	9.5	109 134.8	82 x 62	M10 x 13	80 105.8	M6 x 1	8	6.5	34	29	80	9 x 14 x 12	4000	20	3960 5230	7010 9270	96 125	75 95	73 95	1.6 2	7.2
BRH45A BRH45AL	60	120	37.5	14	138.2 163	100 x 80	M12 x 15	105 129.8	M8 x 1	10	13	45	38	105	14 x 20 x 17	4000	22.5	6740 8330	12100 14950	216 267	170 210	168 210	2.7 3.6	12.3

Please refer to the "Technical Data" section on page 5 for screw specifications.

STANDARD, WITHOUT FLANGE (BRH-XX-B & BL)

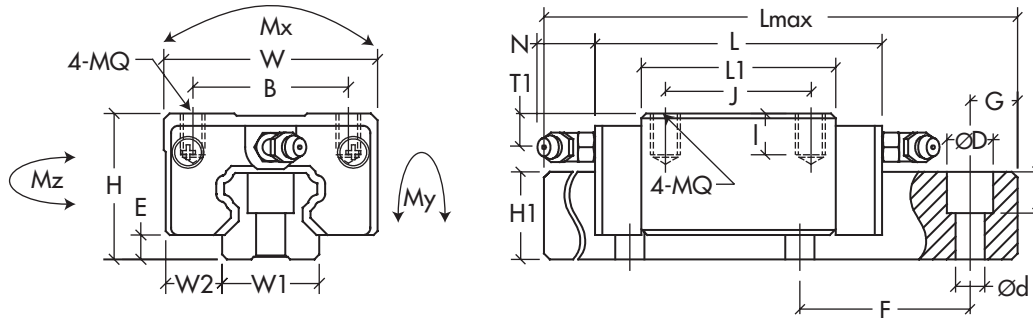

PART NUMBER	ASSEMBLY (mm)				CARRIAGE (mm)								RAIL (mm)					BASIC LOAD RATING (kg-f)		STATIC MOMENT (kg-f*m)			WEIGHT (kg-f)	
	H	W	W2	E	L	B x J	MQ x l	L1	Oil Hole	T1	N	W1	H1	F	d x D x h	Lmax	G	C	Co	Mx	My	Mz	CARRIAGE (kg-f)	RAIL (kg-f/m)
BRH15B	28	34	9.5	4.6	66	26 x 26	M4 x 6.4	40	ø3	8.3	5	15	14	60	4.5 x 7.5 x 5.3	4000	20	850	1650	10	8	8	0.19	1.4
BRH20B BRH20BL	30	44	12	5	77.8 92.4	32 x 36 32 x 50	M5 x 8	48.8 63.4	M6 x 1	7	6.5	20	18	60	6 x 9.5 x 8.5	4000	20	1450 1900	2560 3330	22 28.6	18 23.4	18 23.4	0.31 0.47	2.6
BRH25B BRH25BL	40	48	12.5	7	88 110.1	35 x 35 35 x 50	M6 x 9.6	57 79.1	M6 x 1	11.8	6.5	23	22	60	7 x 11 x 9	4000	20	2140 2996	4000 5600	36 50.4	32 44.8	31 43.4	0.45 0.56	3.6
BRH30B BRH30BL	45	60	16	9	109 131.3	40 x 40 40 x 60	M8 x 12.8	72 94.3	M6 x 1	10	6.5	28	26	80	9 x 14 x 12	4000	20	2980 3900	5490 7190	60 78.5	50 65	49 65	0.91 1.2	5.2
BRH35B BRH35BL	55	70	18	9.5	109 134.8	50 x 50 50 x 72	M8 x 12.8	80 105.8	M6 x 1	15	6.5	34	29	80	9 x 14 x 12	4000	20	3960 5230	7010 9270	96 125	75 95	73 95	1.5 1.9	7.2
BRH45B BRH45BL	70	86	20.5	14	138.2 163	60 x 60 60 x 80	M10 x 16	105 129.8	M8 x 1	18	13	45	38	105	14 x 20 x 17	4000	22.5	6740 8330	12100 14950	216 267	170 210	168 210	2.3 2.8	12.3

STANDARD, THRU HOLES, WITH FLANGE (BRH-XX-C & CL)

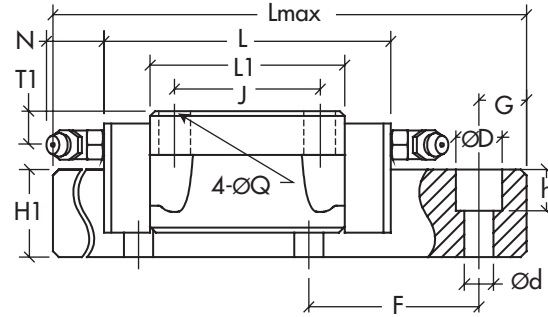
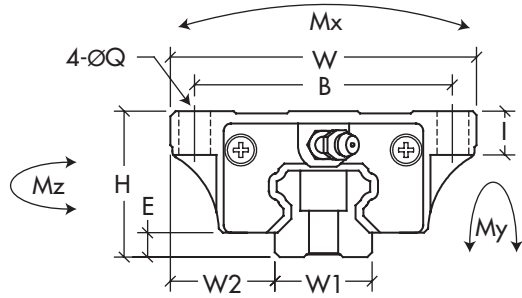

PART NUMBER	ASSEMBLY (mm)				CARRIAGE (mm)							RAIL (mm)						BASIC LOAD RATING (kg-f)		STATIC MOMENT (kg-f*m)			WEIGHT (kg-f)	
	H	W	W2	E	L	B x J	ØQ x l	L1	Oil Hole	T1	N	W1	H1	F	d x D x h	Lmax	G	C	Co	Mx	My	Mz	CARRIAGE (kg-f)	RAIL (kg-f/m)
BRH15C	24	47	16	4.6	66	38 x 30	Ø4.5 x 8	40	Ø3	4.3	5	15	14	60	4.5 x 7.5 x 5.3	4000	20	850	1650	10	8	8	0.21	1.4
BRH20C	30	63	21.5	5	77.8	53 x 40	Ø5.5 x 9	48.8	M6 x 1	5	6.5	20	18	60	6 x 9.5 x 8.5	4000	20	1450	2560	22	18	18	0.4	2.6
BRH20CL					92.4			63.4										28.6	23.4	23.4	0.52			
BRH25C	36	70	23.5	7	88	57 x 45	Ø7 x 12	57	M6 x 1	5	6.5	23	22	60	7 x 11 x 9	4000	20	2140	4000	36	32	31	0.57	3.6
BRH25CL					110.1			79.1										50.4	44.8	43.4	0.72			
BRH30C	42	90	31	9	109	72 x 52	Ø9 x 12	72	M6 x 1	7	6.5	28	26	80	9 x 14 x 12	4000	20	2980	5490	60	50	49	1.1	5.2
BRH30CL					131.3			94.3										78.5	65	65	1.4			

LOW ASSEMBLY, WITHOUT FLANGE (BRS-XX-B, BL, & BS)

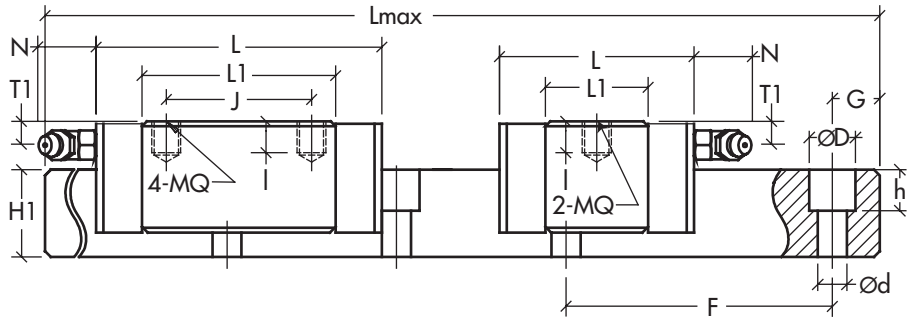
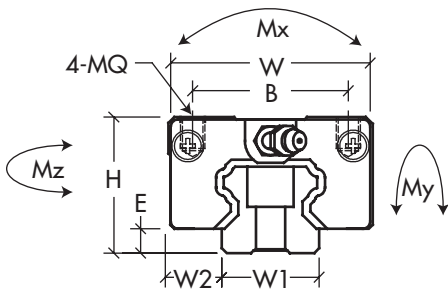

PART NUMBER	ASSEMBLY (mm)				CARRIAGE (mm)							RAIL (mm)						BASIC LOAD RATING (kg-f)		STATIC MOMENT (kg-f*m)			WEIGHT (kg-f)	
	H	W	W2	E	L	B x J	MQ x l	L1	Oil Hole	T1	N	W1	H1	F	d x D x h	Lmax	G	C	Co	Mx	My	Mz	CARRIAGE (kg-f)	RAIL (kg-f/m)
BRS15B	24	34	9.5	4.6	66	26 x 26	M4 x 5.6	40	Ø3	4.3	5	15	14	60	4.5 x 7.5 x 5.3	4000	20	850	1650	10	8	8	0.17	1.4
BRS15BS					47.6	26 x -		21.6										6	4.8	4.8	0.1			
BRS20B	28	42	11	5	77.8	32 x 32	M5 x 7	48.8	M6 x 1	5	6.5	20	18	60	6 x 9.5 x 8.5	4000	20	1450	2560	22	18	18	0.26	2.6
BRS20BS					57	32 x -		28										12.6	10.3	10.3	0.17			
BRS25B	33	48	12.5	7	88	35 x 35	M6 x 8.4	57	M6 x 1	4.8	6.5	23	22	60	7 x 11 x 9	4000	20	2140	4000	36	32	31	0.38	3.6
BRS25BS					62.5	35 x -		31.5										20	17.5	17.2	0.21			
BRS25BL					110.1	35 x 50	79.1											2996	5600	50.4	44.8	43.4	0.53	
BRS30B	42	60	16	9	109	40 x 40	M8 x 11.2	72	M6 x 1	7	6.5	28	26	80	9 x 14 x 12	4000	20	2980	5490	60	50	49	0.81	5.2
BSR30BS					75.6	40 x -		38.6										32	27	27	0.48			
BRS30BL					131.3	40 x 60	94.3											3900	7190	78.5	65	65	1.06	
BRS35B	48	70	18	9.5	109	50 x 50	M8 x 11.2	80	M6 x 1	8	6.5	34	29	80	9 x 14 x 12	4000	20	3960	7010	96	75	73	1.2	7.2
BRS35BS					74.7	50 x -		45.7										54.5	42.5	41.5	0.8			
BRS35BL					134.8	50 x 72	105.8											5230	9270	125	95	95	1.6	
BRS45B	60	86	20.5	14	138.2	60 x 60	M10 x 14	105	M8 x 1	8.5	13	45	38	105	14 x 20 x 17	4000	22.5	6740	12100	216	170	168	2.1	12.3
BRS45BL					163	60 x 80		129.8										267	210	210	2.6			

LOW ASSEMBLY, WITH FLANGE (BRS-XX-A & AS)

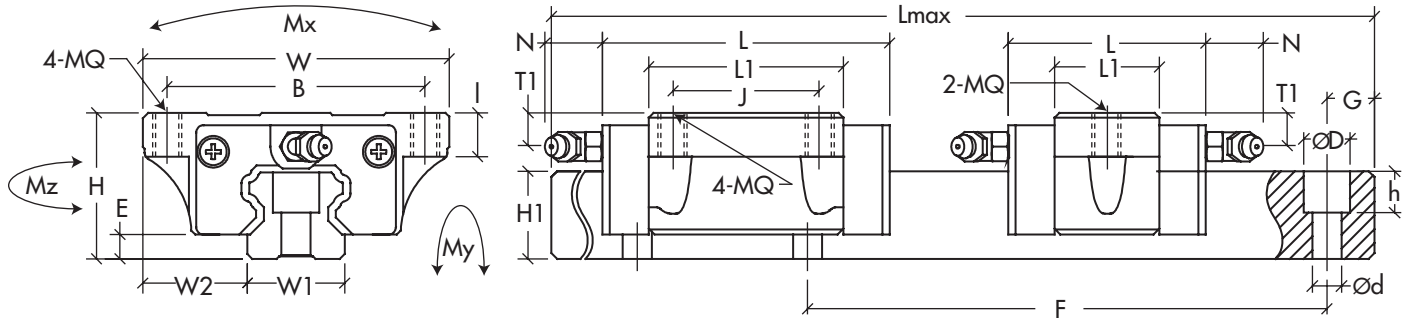

PART NUMBER	ASSEMBLY (mm)				CARRIAGE (mm)								RAIL (mm)					BASIC LOAD RATING (kg-f)		STATIC MOMENT (kg-f*m)			WEIGHT (kg-f)	
	H	W	W2	E	L	B x J	MQ x l	L1	Oil Hole	T1	N	W1	H1	F	d x D x h	Lmax	G	C	Co	Mx	My	Mz	CARRIAGE (kg-f)	RAIL (kg-f/m)
BRS20AS	28	59	19.5	5	57	49	M6 x 7	28	M6 x 1	5	6.5	20	18	60	6 x 9.5 x 8.5	4000	20	830	1470	12.6	10.3	10.3	0.17	2.6
BRS25A BRS25AS	33	73	25	7	88 62.5	60 x 35 60	M8 x 9	57 31.5	M6 x 1	4.8	6.5	23	22	60	7 x 11 x 9	4000	20	2140 1190	4000 2230	36 20	32 17.5	31 17.2	0.5 0.33	3.6

LOW ASSEMBLY, THRU HOLES, WITH FLANGE (BRS-XX-C & CS)

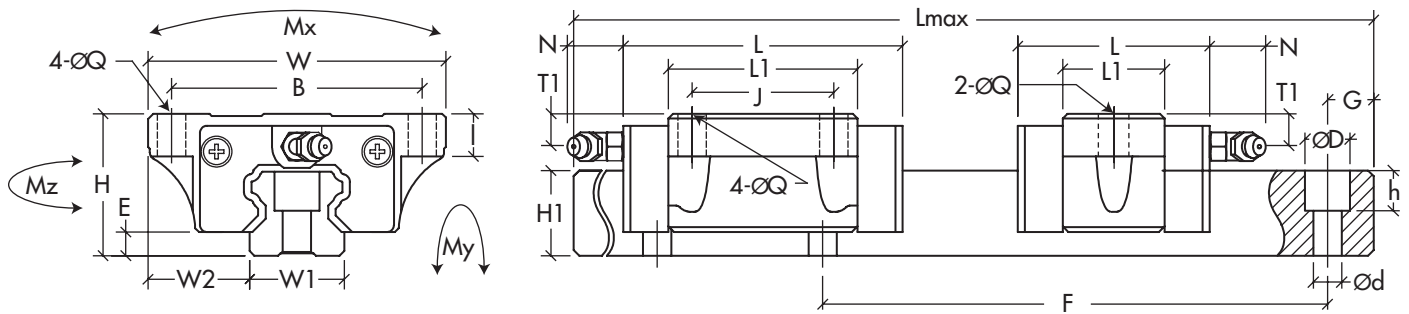

PART NUMBER	ASSEMBLY (mm)				CARRIAGE (mm)								RAIL (mm)					BASIC LOAD RATING (kg-f)		STATIC MOMENT (kg-f*m)			WEIGHT (kg-f)	
	H	W	W2	E	L	B x J	ØQ x l	L1	Oil Hole	T1	N	W1	H1	F	d x D x h	Lmax	G	C	Co	Mx	My	Mz	CARRIAGE (kg-f)	RAIL (kg-f/m)
BRS20CS	28	59	19.5	5	57	49	Ø5.5 x 7	28	M6 x 1	5	6.5	20	18	60	6 x 9.5 x 8.5	4000	20	830	1470	12.6	10.3	10.3	0.17	2.6
BRS25C BRS25CS	33	73	25	7	88 62.5	60 x 35 60	Ø7 x 9	57 31.5	M6 x 1	4.8	6.5	23	22	60	7 x 11 x 9	4000	20	2140 1190	4000 2230	36 20	32 17.5	31 17.2	0.5 0.33	3.6

CUSTOM DESIGN (BRX-XX-B & BL)

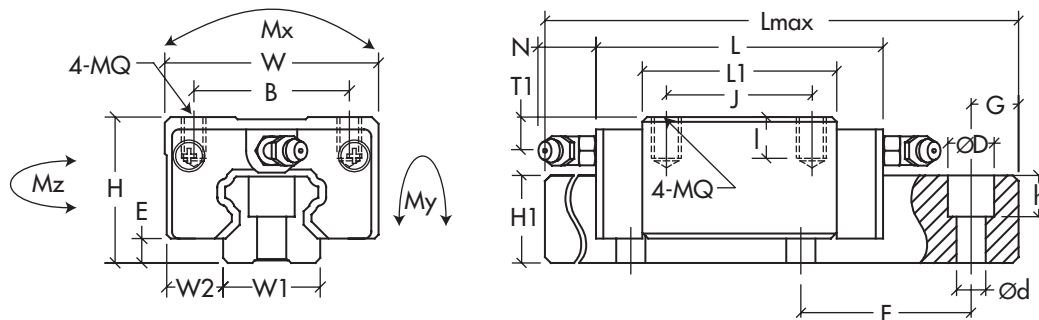

PART NUMBER	ASSEMBLY (mm)				CARRIAGE (mm)								RAIL (mm)					BASIC LOAD RATING (kg-f)		STATIC MOMENT (kg-f*m)			WEIGHT (kg-f)	
	H	W	W2	E	L	B x J	MQ x l	L1	Oil Hole	T1	N	W1	H1	F	d x D x h	Lmax	G	C	Co	Mx	My	Mz	CARRIAGE (kg-f)	RAIL (kg-f/m)
BRX25B BRX25BL	36	48	12.5	7	88 110.1	35 x 35 35 x 50	M6 x 9.6	57 79.1	M6 x 1	5	6.5	23	22	60	7 x 11 x 9	4000	20	2140 2996	4000 5600	36 50.4	32 44.8	31 43.4	0.4 0.5	3.6

Assembly and Accuracy

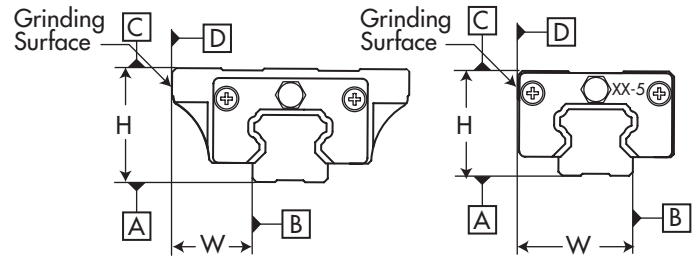
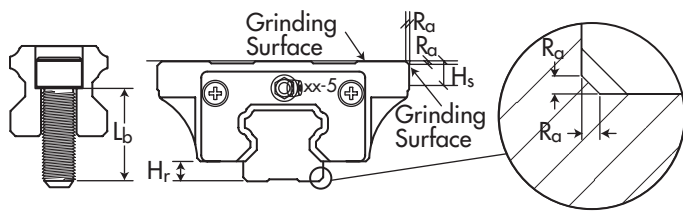

In mm PART NUMBER	MAX. FILLET (Ra)	MAX. HEIGHT RAIL SHOULDER (Hr)	MAX. HEIGHT BLOCK SHOULDER (Hs)	SUGG. RAIL BOLT LENGTH (Lb)
BR-15	0.8	4.0	5.0	M4 * 16
BR-20	0.8	4.5	6.0	M5 * 20
BR-25	1.2	6.0	7.0	M6 * 25
BR-30	1.2	8.0	8.0	M8 * 30
BR-35	1.2	8.5	9.0	M8 * 30
BR-45	1.6	12.0	11.0	M12 * 40
BR-55	1.6	13.0	12.0	M14 * 45

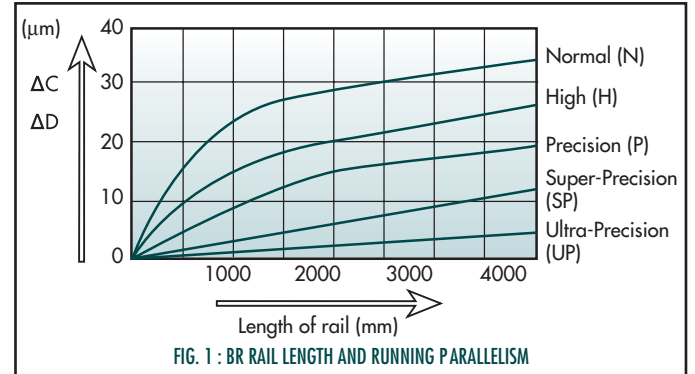

In mm	PRECISION CLASS				
	NORMAL (N)	HIGH (H)	PRECISION (P)	SUPER PRECISION (SP)	ULTRA-PRECISION (UP)
Height Tolerance (H)	± 0.1	± 0.04	0 / -0.04	0 / -0.02	0 / -0.01
Width Tolerance (W)	± 0.1	± 0.04	0 / -0.04	0 / -0.02	0 / -0.01
Height differential (Δ H)	0.03	0.02	0.01	0.005	0.003
Width differential (Δ W)	0.03	0.02	0.01	0.005	0.003
Parallelism (between carriage surfaces A and C)	Δ C - Refer to Fig. 1				
Parallelism (between carriage surfaces B and D)	Δ D - Refer to Fig. 1				

Frictional Resistance

The frictional resistance can be calculated with the following formula.

$$F = u * W + f$$

F : frictional resistance

W : load

u : coefficient of friction

f : seal resistance

f : SEAL RESISTANCE

PART NUMBER	RESISTANCE (kg-f)
BR-15	0.3
BR-20	0.4
BR-25	0.4
BR-30	0.5
BR-35	0.7
BR-45	0.9
BR-55	1.0

u : COEFFICIENT OF FRICTION

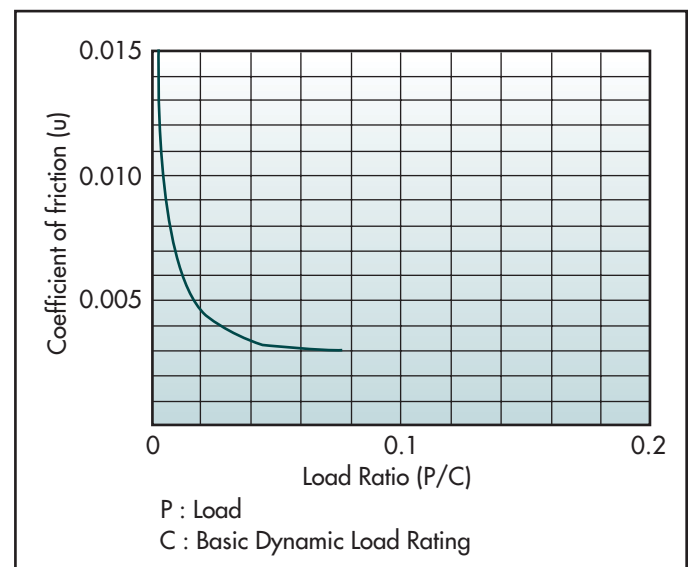

NOMINAL LIFE CALCULATION : L

Given the basic dynamic load rating C and the applied load P, the following formula calculates the nominal life, L, of a linear motion system using steel balls.

$$L = \left(\frac{f_h * f_t * f_c}{f_w} * \frac{C}{P} \right)^3 * 50$$

L : nominal life
C : basic dynamic load rating
P : applied load

f_h : hardness factor
f_t : temperature factor
f_c : contact factor
f_w : load factor

Hardness Coefficient : f_h

The desired hardness of the rail is HRC58-64 for optimum load capacity. For a hardness under HRC58, the basic static and dynamic load ratings should be multiplied by f_h.

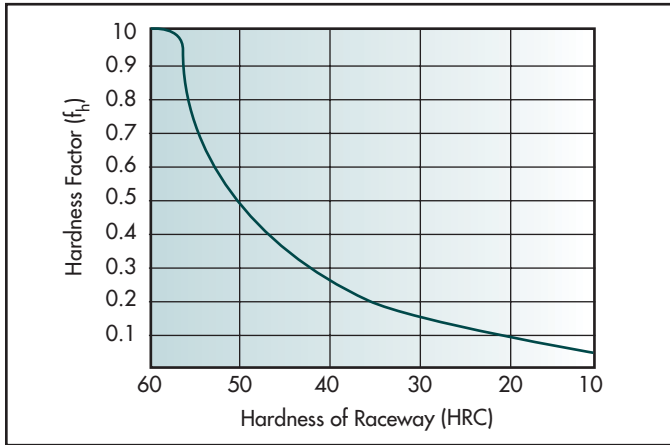

Temperature Coefficient : f_t

For temperatures over 100° C, apply the appropriate f_t.

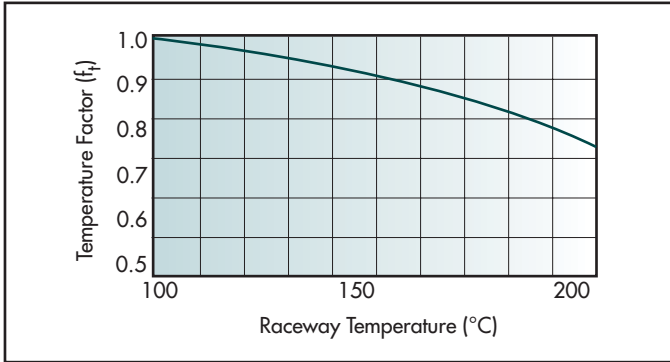

Note 1: When used in an environment over 80°C, the seals and end plates should be designed for high temperature operation.

Note 2: When used above 120°C, thermal expansion will require further design consideration.

Load Coefficient : f_w

IMPACT AND VIBRATION	SPEED (V)	MEASURED VIBRATION (G)	f _w
No external impact or vibration	At low speed V ≤ 15 m/min	G ≤ 0.5	1 - 1.5
No significant impact or vibration	At medium speed 15 < V ≤ 60 m/min	0.5 < G ≤ 1.0	1.5 - 2.0
With external impact or vibration	At high speed V > 60 m/min	1.0 < G ≤ 2.0	2.0 - 3.5

Preload Grade

	FORCE
Clearance (ZF)	0
No preload (Z0)	0
Light preload (Z1)	0.02 C
Middle preload (Z2)	0.05 C
Heavy preload (Z3)	0.07 C

Basic static load rating (C₀) is defined as

a static load of constant magnitude acting in one direction under which the sum of the permanent deformations of rolling elements and raceway equals 0.0001 times the diameter of the rolling elements.

Basic dynamic load rating (C). When individual, yet identical linear motion systems are applied independently under the same conditions, the basic dynamic load rating, C, is a load of constant magnitude acting in one direction that results in a nominal life of 50 km.

Contact Coefficient : f_c

Use the contact coefficient f_c when multiple carriages are applied to the same rail.

NO. OF CARRIAGES ON RAIL	CONTACT FACTOR
2	0.81
3	0.72
4	0.66
5	0.61
Normal operation	1

Static Safety Coefficient : f_s

$$f_s = (f_c * C_0) / P \text{ or } f_s = f_c * M_0 / M$$

f_s : static safety coefficient

f_c : contact coefficient

C₀ : basic static load rating

P : design load

M₀ : permissible static moment

M : design moment

OPERATING CONDITION	LOAD CONDITION	MINIMUM
Normally stationary	Small impact and deflection	1.0 - 1.3
	Impact or twisting load is applied	2.0 - 3.0
Normally moving	Small impact or twisting load is applied	1.0 - 1.5
	Impact or twisting load is applied	2.5 - 5.0

MANUFACTURING • DISTRIBUTION • GLOBAL PROCUREMENT

International Distribution Alliance (IDA), Inc. manufactures and procures high quality power transmission products on a global scale.

At IDA, the business philosophy is profoundly simple. Based on the onus of building the foundation for healthy families, communities and relationships, IDA embraces ideals of respect, courtesy and commitment.

Commitment to Quality Product

We are a versatile organization with the ability to design and manufacture high quality industrial products for OEMs, distributors and catalog houses economically and efficiently.

Commitment to Customer Service

Count on us for fast response to your business needs. We go all-out to deliver reliable information and product - on time, every time.

Commitment to Community

We're more than just a name. We are people, like you, working to serve each other to build strong individuals with a sound future. That is why IDA invests in local schools, apprenticeship programs and provides an environment for students, skilled workers and master craftsmen to find growth and fulfillment.

It is this commitment that creates immediate and long-term value for business partners, customers and employees.

Headquarters:
Rockford, Illinois USA



Uniting business - one person at a time



**BALL BUSHINGS
SHAFTING & ACCESSORIES**



**TRACK ROLLERS &
ACCESSORIES**



IDA, Inc.

2330 20th Avenue • Rockford, Illinois 61104 USA
Phone: +1 (815)227-9010 • Fax: +1 (815)227-9012
E-mail: sales@idamotion.com